

1.	Nondestructive Testing		
1.1	Pressure Test	Mandatory	Yes
1.2	Chemical Composition Certification (PMI)	Mandatory	Yes
1.3	Penetrant Test	Mandatory	Yes
1.4	Magnetic Particle Test	Mandatory	Yes

Performance Standard		
Nominal Bore	2"~24"	NPS
Nominal Pressure	150	Lb
Pressure test		
Shell Test	3.0	MPa
Seal Test	2.2	
Backseat test	--	
Air Test	0.6	
Working Temperature	-29°C ~ +150°C	
Suitable Medium	Water.Oil.Gas.Steam. etc	

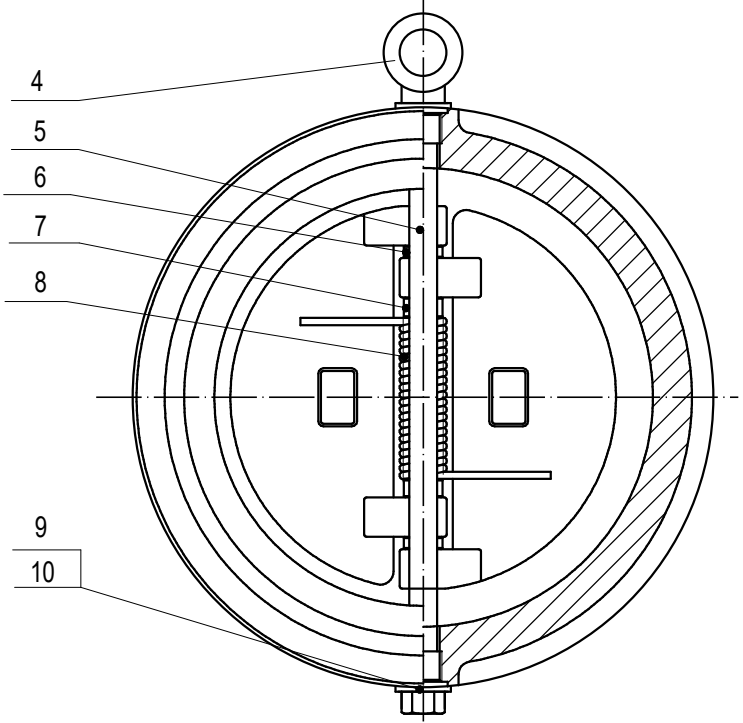

Technical Requirements

1. Design & manufacture conform to API 594
2. Pressure & Temperature conform to ASME B16.34
3. Between Flange dimension conforms to ASME B16.5
4. Face to Face dimension conforms to API 594
5. Test & Inspect conform to API 598
6. Visual Examination conforms to: 100% MSS SP-55

NPS	L	D	D1	D2
2"	60	103	51	58
2 1/2"	67	122	65	73
3"	73	135	80	88
4"	73	173	102	108
5"	86	195	127	132
6"	98	220	152	160
8"	127	277	203	210

NPS	L	D	D1	D2
10"	146	337	254	266
12"	181	407	305	310
14"	184	448	350	355
16"	191	512	400	405
18"	203	547	450	455
20"	219	604	500	505
24"	222	715	600	605

10	Bolt	A193 B7	
9	Gasket	13Cr	
8	Spring	A276 SS316	
7	Spring Plate	A182 F316	
6	Spacer	A276 SS316	
5	Shaft	A182 F316	
4	Lifting Lug	AISI 1025	
3	Body	Ductile Iron ASTM A536	
2	Seat	EPDM	
1	Disc	A351 CF8M	

No.	Name	Material	Remark
TAG NO.:			
		SBM PTV	
Design	Approve	Graphics	Genral View
Technics	Date	Describe	Dual Plate Wafer Check valve
Check		Model	NPS 2"~24" Class 150 LB DI/SS316/EPDM